

## VARIMETER Motor Load Monitor MK 9397N, MH 9397



### Product description

The Load monitor MK9397 and MH9397 of the varimeter family monitor reliably the load of motors as well as the function of 3 phase electrical users.

If the measured value falls under or goes over the adjusted settings the corresponding output relay is energised. To avoid unnecessary tripping a response delay  $t_v$  can be adjusted between 0 and 10 s. LEDs show the status of the output relays.

### Your Advantage

- Preventive maintenance
- For a evaluate time
- Quicker fault locating
- Precise and reliable
- Overload detection, as option also with prewarning
- Can also be used for underload monitoring
- Simple adjustment and fault diagnostics
- Space and cost saving

### Features

- According to EN 60255-1
- Active power measuring
- Relay output  
MK 9397N: 1 changeover contact  
MH 9397: 1 changeover contact each for overload and prewarning
- On delay
- Closed circuit operation
- As option open circuit operation
- As option with plugable terminal blocks for easy exchange of devices
  - with screw terminals
  - or with cage clamp terminals
- MK 9397N: Width 22,5 mm  
MH 9397: Width 45 mm

### Function Diagram

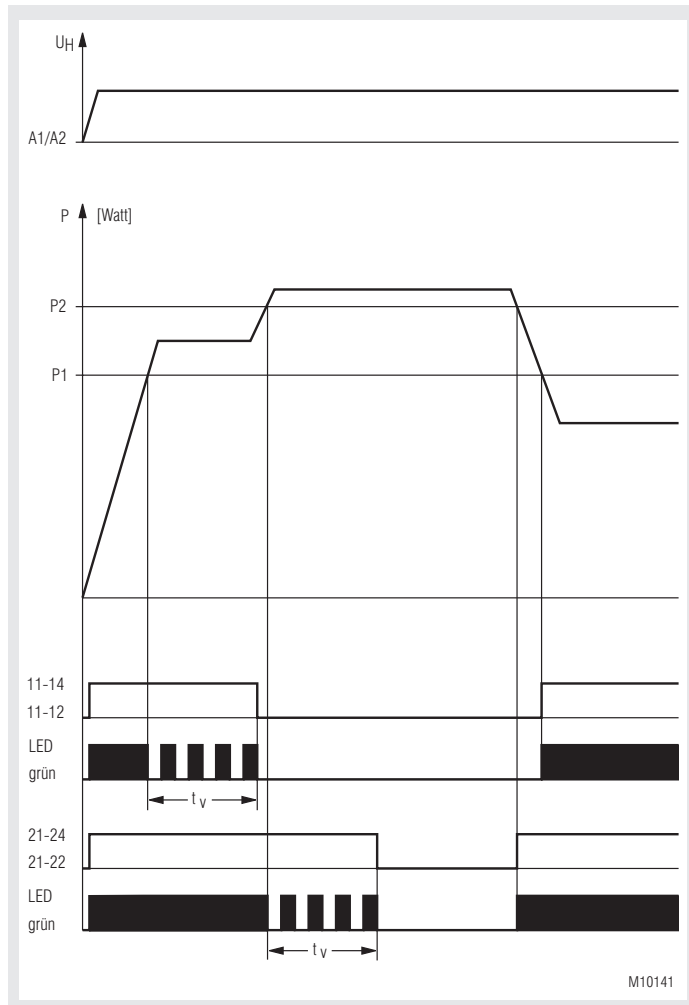

### Approvals and Markings



### Application

The load monitor is suitable to monitor industrial motors with variable load as well as to monitor the correct function of electrical users. The units can detect in time wearing or failures on machines and tools. So maintenance can be carried out before a plant stops.

### Function

The load monitor monitors the effective power of electrical consumers. As the current is only measured in one phase a symmetric load in a 3 phases is assumed. as it is usual with motors. The setting value is adjusted with potentiometers, the range selection by rotational switches. The MH 9397 has 2 response values (e.g. for prewarning).

## Circuit Diagrams

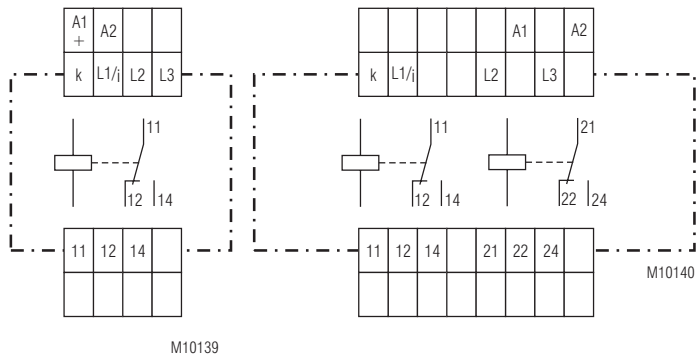

MK 9397N

MH 9397

## Connection Terminals

Terminal designation	Signal designation
A1 / A2	Auxiliary voltage
K / L1/i	Current path (current at phase L1)
L1 / L2 / L3	Supply
11 / 12 / 14	Contacts relay 1
21 / 22 / 24	Contacts relay 2 (only at MH 9397)

## Connection notes

The unit can also be used on single phase loads. the terminals L2 and L3 have to be bridged in this case. The device also switches at the set points in the case of reverse power. Overload in the current path is indicated by fast flashing of the LEDs.

## Geräteanschluss

The connection has to be done according to the connection diagrams. To connect the motor current of L1 the terminals i and k are used.. For current exceeding the limits of the device an additional current transformer has to be used.

## Setting

2 rotational switches for P<sub>1</sub>

rotary switch 1:

rotary switch 2:

fine adjustment

8 ranges adjustable:

0 ... 1 kW

1 ... 2 kW

2 ... 3 kW

:

7 ... 8 kW

2 rotational switches for P<sub>2</sub>

rotary switch 3:

rotary switch 4:

fine adjustment

8 ranges adjustable:

0 ... 1 kW

1 ... 2 kW

2 ... 3 kW

:

7 ... 8 kW

rotary switch t<sub>r</sub>:

0 ... 10 s

## Example

Response value: 5.2 kW

fine adjustment

(upper rotary switch):

0,2 kW



## Bereichswahl

(lower rotary switch):

5 ... 6 kW



## Indication

The LED indicate the state.

green LED, UN: on, when auxiliary voltage present

green LED, P1: flashes: during time delay  
permanently on: Relay 1 active

(only at MH 9397)

green LED, P2: flashes: during time delay  
permanently on: Relais 2 active

Overload within the current range is indicated by fast flashing of the LED.

## Technical Data

### Auxiliary Voltage A1 / A2

#### Nominal auxiliary voltage $U_H$ :

MK 9397N: DC 24 V (0.9 ... 1.1 x  $U_H$ )  
MH 9397: AC 230V (0.8 ... 1.1 x  $U_H$ )

**Nominal frequency:** 50 / 60 Hz

**Frequency range:** 45 ... 400 Hz

#### Input current:

at DC 24V: 50 mA

at AC 230V: 15 mA

### Voltage Measuring Input L1 / L2 / L3

**Nominal voltage  $U_N$ :** 3 AC 400 V

**Measuring range:** 3 AC 12 ... 400 V

Variants without auxiliary supply get their power from the measuring input. The Voltage range of the Measuring voltage is then identical with the range of the auxiliary supply.

### Current Measuring Input i / k

**Nominal current  $I_N$ :** AC 12 A

**Measuring range:** AC 100 mA ... 12 A

#### Max. overload

continuously: 16 A

short time < 10 s: max. 25 A

Overload within the current range is indicated by fast flashing of the LED.

**Nominal frequency:** 50 / 60 Hz

**Frequency range:** 45 ... 400 Hz

### Setting range (at absolute scale)

**Rel 1:** fine adjustment

**Range:** 8 ranges 0 ... 8 kW

**Rel 2:** fine adjustment

**Range:** 8 ranges 0 ... 8 kW

#### Measuring accuracy

**at nominal frequency**  
(in % of setting value):  $\pm 4\%$

**Hysteresis**  
(in % of setting value): < 5 %

**Reaction time:** < 150 ms

**Time delay  $t_d$ :** 0 ... 10 s adjustable

**Start up delay:** 500 ms fixed

### Output Circuit (Rel1: 11/12/14; Rel2: 21/22/24)

#### Contacts

MK 9397N: 1 changeover contact for P1

MH 9397: 1 changeover contact for P1 and

1 changeover contact for P2

**Thermal current  $I_{th}$ :** 2 x 4 A

#### Switching capacity

to AC 15:

NO contacts: 3 A / AC 230 V IEC/EN 60 947-5-1

NC contacts: 1 A / AC 230 V IEC/EN 60 947-5-1

#### Electrical life

to AC 15 at 3 A, AC 230 V: 2 x 10<sup>5</sup> switch. cycl. IEC/EN 60 947-5-1

#### Permissible switching

**frequency:** 1800 switching cycles / h

#### Short circuit strength

**max. fuse rating:** 4 A gL IEC/EN 60 947-5-1

**Mechanical life:** 30 x 10<sup>6</sup> switching cycles

## Technical Data

### General Data

**Nominal operating mode:** continuous operation

**Temperature range:** - 20 ... + 60°C

**Clearance and creepage distance**  
**rated impulse voltage /**

**pollution degree:** 4 kV / 2

**high voltage test:** IEC/EN 60 664-1

#### EMC

Electrostatic discharge (ESD): 8 kV (air) IEC/EN 61 000-4-2

HF irradiation: 10 V / m IEC/EN 61 000-4-3

Fast transients: 2 kV IEC/EN 61 000-4-4

Surge voltage

between

wires for power supply: 1 kV IEC/EN 61 000-4-5

between wire and ground: 2 kV IEC/EN 61 000-4-5

HF-wire guided: 10 V IEC/EN 61 000-4-6

Interference suppression: Limit value class A EN 55 011

#### Degree of protection:

Housing: IP 40 IEC/EN 60 529

Terminals: IP 20 IEC/EN 60 529

**Housing:** thermoplastic with VO behaviour

according to UL Subject 94

Amplitude 0,35 mm

frequency 10 ... 55 Hz, IEC/EN 60 068-2-6

20 / 060 / 04 IEC/EN 60 068-1

DIN 46 228-1/-2/-3/-4

#### Vibration resistance:

#### Climate resistance:

#### Wire connection

#### Screw terminal

#### (fixed):

1 x 4 mm<sup>2</sup> solid or

1 x 2.5 mm<sup>2</sup> stranded ferruled (isolated) or

2 x 1.5 mm<sup>2</sup> stranded ferruled (isolated) or

2 x 2.5 mm<sup>2</sup> solid

Insulation of wires or

sleeve length:

8 mm

#### Terminal block

#### with screw terminals

Max. cross section:

1 x 2.5 mm<sup>2</sup> solid or

1 x 2.5 mm<sup>2</sup> stranded ferruled (isolated)

Insulation of wires or

sleeve length:

8 mm

#### Terminal block

#### with cage clamp terminals

Max. cross section:

1 x 4 mm<sup>2</sup> solid or

1 x 2.5 mm<sup>2</sup> stranded ferruled (isolated)

0.5 mm<sup>2</sup>

Min. cross section:

Insulation of wires or

sleeve length:

12  $\pm 0.5$  mm

#### Wire fixing:

Plus-minus terminal screws M3,5 box

terminals with wire protection

or cage clamp terminals

0.8 Nm

#### Fixing torque:

#### Mounting:

DIN rail

IEC/EN 60 715

#### Weight:

360 g

### Dimensions

#### Width x height x depth:

MK 9397N: 22.5 x 90 x 99 mm

MH 9397: 45 x 90 x 99 mm

## Standard Types

MK 9397N.11/010 3 AC 24 ... 400 V AC 12 A DC 24 V 10 s

- Article number: 0062043
- Measuring voltage: 3 AC 24 ... 400 V
  - Measuring current: AC 12 A
  - Auxiliary voltage  $U_H$ : DC 24 V
  - On delay: up to 10 s
  - Output: 1 changeover contact
  - Width: 22,5 mm

MH 9397.12/010 3 AC 24 ... 400 V AC 12 A AC 230 V 10 s

- Article number: 0062046
- Measuring voltage: 3 AC 24 ... 400 V
  - Measuring current: AC 12 A
  - Auxiliary voltage  $U_H$ : AC 230 V
  - On delay: up to 10 s
  - Output: 1 changeover contact (Rel1) and 1 changeover contact (Rel2)
  - Width: 45 mm

## Ordering Example

MK 9397N .11 /010 3 AC 24 ... 400 V AC 12 A DC 24 V 10 s

- On delay
- Auxiliary voltage  $U_H$
- Measuring current  $U_M$
- Measuring voltage
- Type of terminals
- without indication: terminal blocks fixed with screw terminals
- PC (plug in cage clamp): pluggable terminal blocks with cage clamp terminals
- PS (plug in screw): pluggable terminal blocks with screw terminals
- Contacts
- Type

## Options with Pluggable Terminal Blocks

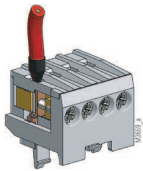

Screw terminal (PS/plugin screw)

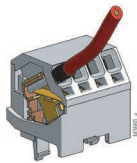

Cage clamp terminal (PC/plugin cage clamp)

## Notes

Removing the terminal blocks with cage clamp terminals

1. The unit has to be disconnected.
2. Insert a screwdriver in the side recess of the front plate.
3. Turn the screwdriver to the right and left.
4. Please note that the terminal blocks have to be mounted on the belonging plug in terminations.

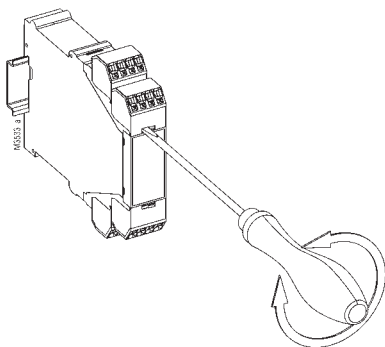

## Connection Example

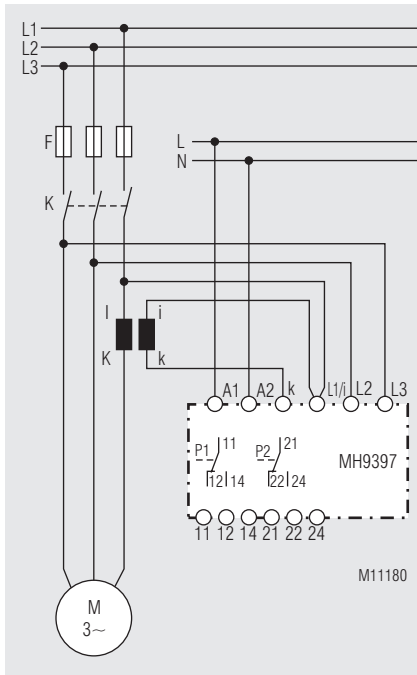
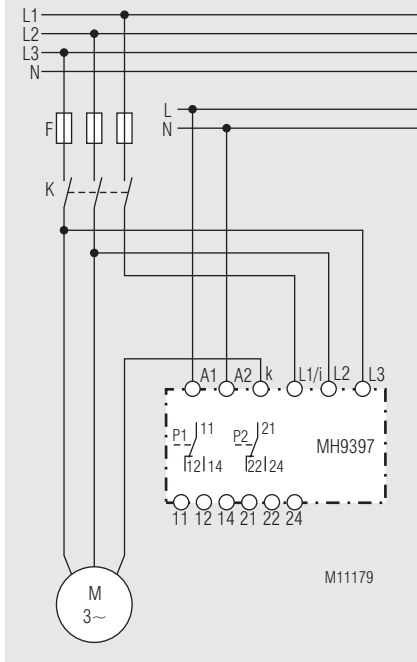

## Remark:

When using external current transformers the setting values have to be multiplied with the transmission ratio  $\ddot{u}$  of the current transformer.

Example: response value = setting value (P1/P2) x  $\ddot{u}$